

# INSTALLATION GUIDE

LAYER OBROUND

# INSTALLING LAYER OBROUND

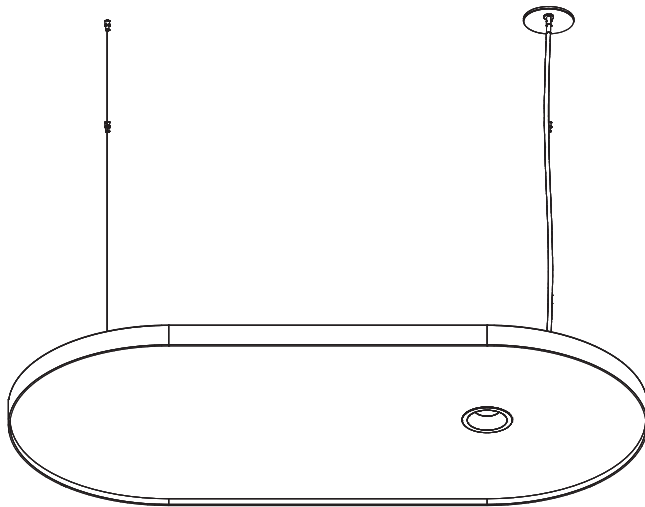

THIS IS A GUIDE TO ASSIST  
WITH YOUR SABIN PRODUCT  
INSTALLATION.

THE FOLLOWING PAGES  
EXPLAIN BEST PRACTICES FOR  
A SUCCESSFUL INSTALLATION.  
PLEASE NOTE THESE ARE NOT  
COMPREHENSIVE TO EVERY  
INSTALLATION ENVIRONMENT.  
PLEASE CONTACT OUR FACTORY  
FOR SPECIFIC QUESTIONS.

# STEPS

- 1 AIRCRAFT CABLE
- 2 SURFACE TYPES
- 3A DRY WALL / HARD SURFACE
- 3B CEILING STRUT
- 3C CEILING GRID
- 4 FIXTURE ADJUSTMENT

# READ PRIOR TO STARTING YOUR INSTALLATION



This product is suitable for indoor dry location only.

Do not switch line voltage until all the wiring is complete.

These products may represent a potential shock or fire hazard if improperly installed.

Products should be installed in accordance with local and National Electric Code (NEC).

This product should only be installed by a licensed Electrician.

Allow air to flow freely around the fixture.

Do not install the Fixture closer than 6.0" to combustible material.

Do not use if there is any damage to the unit or to the wiring/insulation. Inspect periodically.

Confirm the proper gauge wires are used between Power Supplies, Controls & Fixture to avoid voltage drop.

Installer is responsible for reinforcing the walls and/or ceilings to properly support the fixture weight.

Sabin LLC, accepts no responsibility for inadequately reinforced walls and/or ceilings.

# INSTALL THE AIRCRAFT CABLE

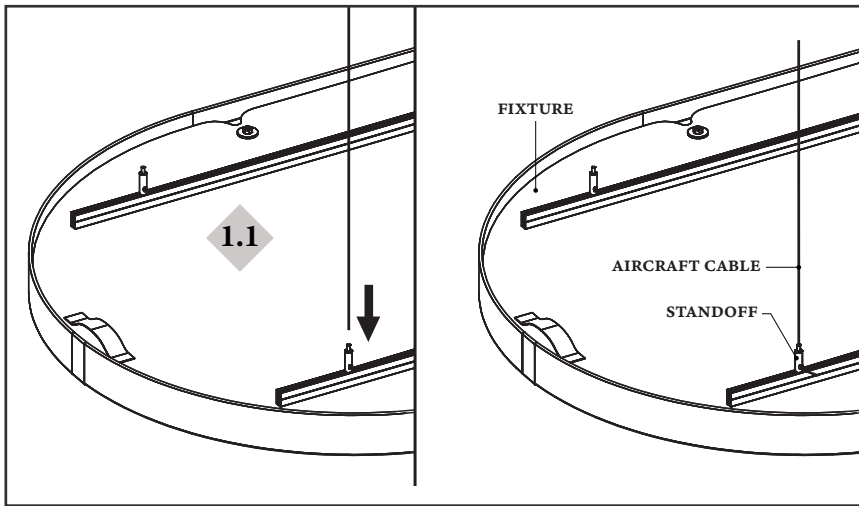

**1.1** FROM THE TOP OF THE FIXTURE, INSERT EACH AIRCRAFT CABLE INTO THE STANDOFF UNTIL THE DESIRED HEIGHT IS ACHIEVED.

# SURFACE TYPES

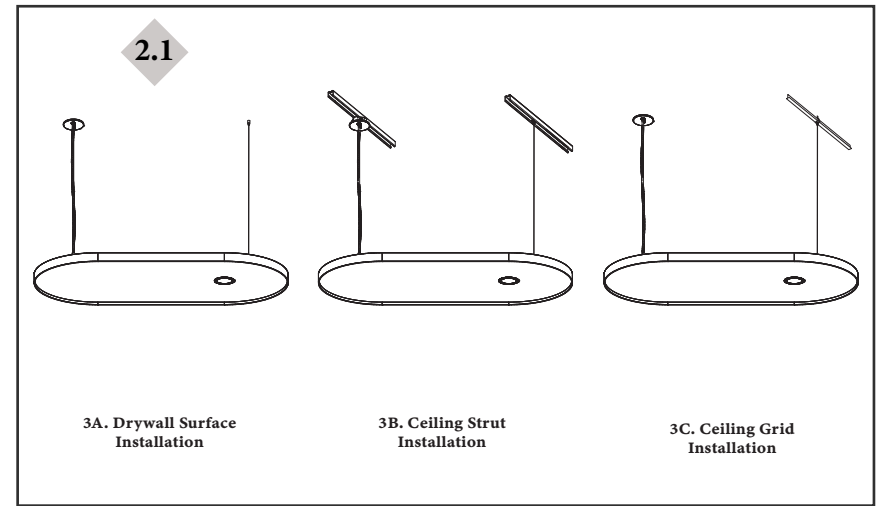

**2.1** TO PROPERLY INSTALL THE FIXTURE REFERENCE 3A, 3B, OR 3C TO COMPLETE THE INSTALLATION DEPENDING ON THE SURFACE TYPE.

# DRYWALL / HARD SURFACE INSTALLATION

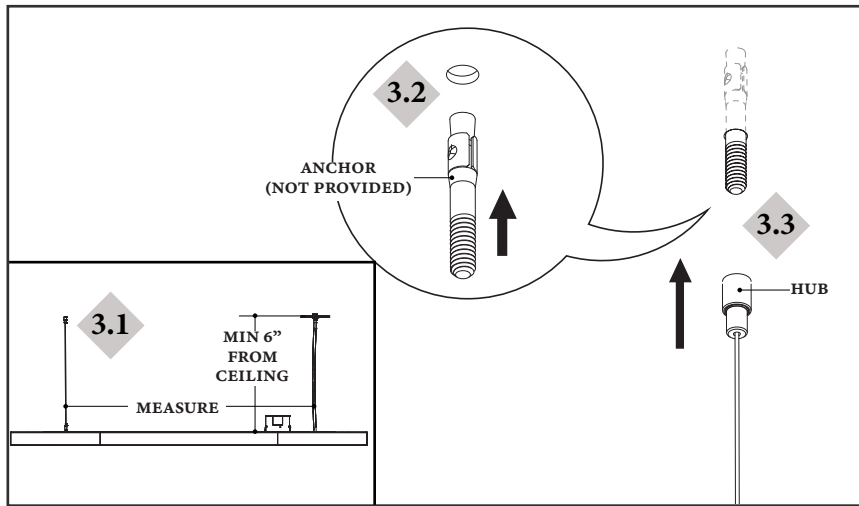

- 3A.1 MEASURE THE DISTANCE BETWEEN THE STANDOFFS, THEN MARK THIS MEASUREMENT TO THE SURFACE.
- 3A.2 INSTALL THE ANCHORS (1/4"-20 ANCHOR, NOT PROVIDED) ONTO THE MARKS OF THE SURFACE.
- 3A.3 SECURE THE AIRCRAFT CABLE HUB TO THE THREADED ROD FOLLOWED BY TIGHTENING.

# CEILING STRUT INSTALLATION

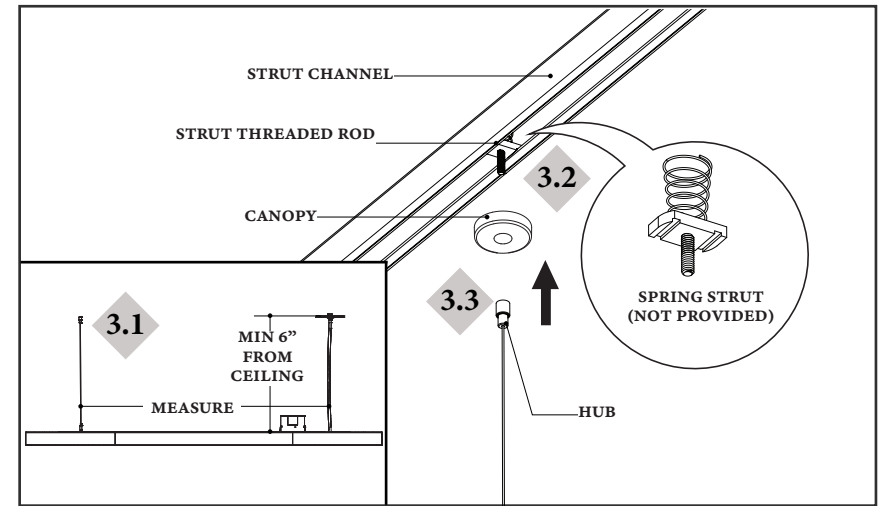

- 3B.1 MEASURE THE DISTANCE BETWEEN THE STANDOFFS, THEN MARK THIS MEASUREMENT TO THE STRUT CHANNEL.
- 3B.2 TWIST & RELEASE EACH STRUT THREADED ROD INTO THE CHANNEL.
- 3B.3 SECURE THE AIRCRAFT CABLE HUB (WITH OR WITHOUT CANOPY) TO THE THREADED ROD FOLLOWED BY TIGHTENING.

# CEILING GRID INSTALLATION

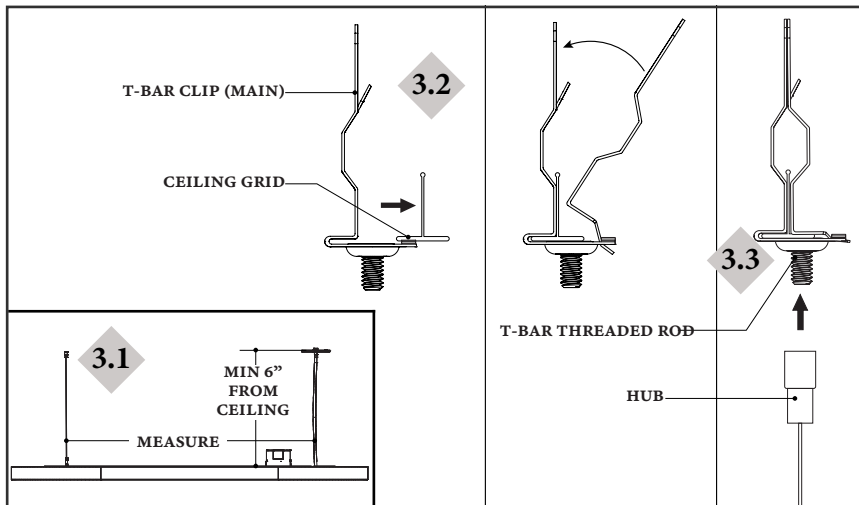

- 3C.1 MEASURE THE DISTANCE BETWEEN THE STANDOFFS, THEN MARK THIS MEASUREMENT ON THE GRID. IF NECESSARY, SLIDE THE T-BAR CLIP OVER IF SOMETHING IS OBSTRUCTING THE MARKED POINT.
- 3C.2 SLIDE THE MAIN PART OF THE T-BAR CLIP ONTO THE GRID. THEN INSERT THE OTHER PART OF CLIP ONTO THE GRID, ROTATE & SNAP IN TO SECURE BOTH SECTIONS INTO PLACE.
- 3C.3 SECURE THE AIRCRAFT CABLE HUB (WITH OR WITHOUT CANOPY) TO THE THREADED ROD FOLLOWED BY TIGHTENING.

# FIXTURE ADJUSTMENT

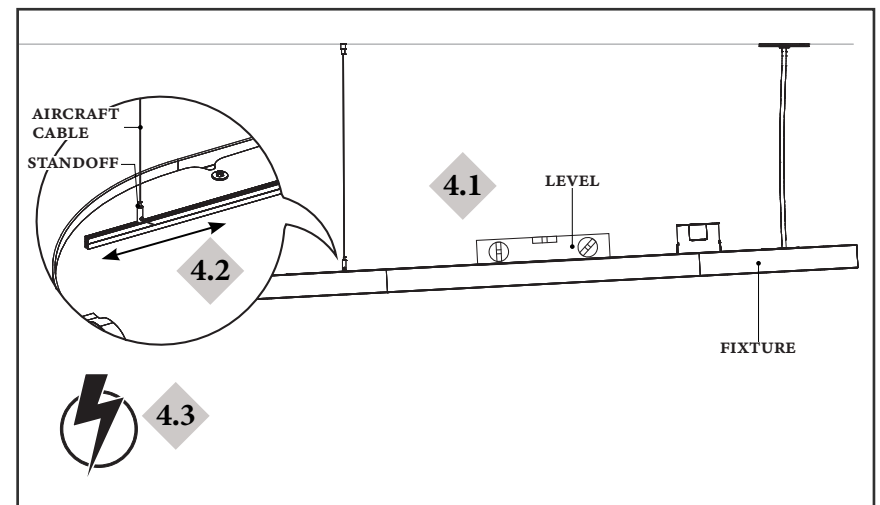

- 4.1 IF THE FIXTURE IS NOT LEVEL, PUSH OR PULL THE AIRCRAFT CABLE THROUGH THE STANDOFFS TO ADJUST.
- 4.2 STANDOFFS HANG POINT CAN BE ADJUSTED BY ROTATING THE STANDOFFS COUNTERCLOCKWISE, SLIDE ALONG THE RAIL TO THE NEW POSITION, THEN RETIGHTEN TO SECURE.
- 4.3 MAKE FIXTURE WIRING CONNECTIONS IN ACCORDANCE WITH LOCAL & NATIONAL ELECTRICAL CODES.

**SABIN**

4447 W CORTLAND ST.  
CHICAGO IL 60637

SABIN.LIGHTING  
© SABIN LLC